

The Road to Euro 6

Phil Moon

Product Marketing Manager



Emissions controls...

Emissions controls...

“Be it known to all within the sound of my voice, whoever shall be found guilty of burning coal shall suffer the loss of his head”

Edward I, King of England 1273



Environmental: CO₂ emissions and air quality ...

Greenhouse gases (CO₂):

- Global warming, sustainability...
 - Reduction of fuel consumption
 - Use of alternative fuels



Noxious matter (NO_x, PM):

- Acid rain, air toxicity, smog, global warming...
 - Technology known and available
 - Harmfulness determined by age vehicle parc



EURO 6

Environmental: air quality and CO₂ emissions...

- Four regulated exhaust emissions:
 - Carbon monoxide (CO)
 - Hydrocarbons (HC)
 - *Nitrogen oxides (NO_x)*
 - *Particulate matter (PM)*



Emission regulation: Euro 6...

PM (g/kWh)

0.40

❖ 1x Euro 3 vehicle ∞ 5x Euro 5 vehicles

❖ 1x Euro 3 vehicle ∞ 10 - 12x Euro 6 vehicles

0.30

0.20

0.10

-97%



Euro 6

1

2

3

4

5

6

7

8

NOx (g/kWh)

-95%

Emission regulation: Euro 6...

- Particle count – necessitates closed wall particulate filter
- World Harmonised test cycles – more realistic, more demanding
 - Includes more low speed, low load
- In-service conformity testing – real life validation
- Emissions system durability
 - Goods vehicles 3.5t to 16t : 300,000km / 6 years
 - Goods vehicles exceeding 16t : 700,000km / 7 years
- Enhanced on-board diagnostics – including anti-tampering measures
- Repair & Maintenance information – to enable diagnosis and correction of problems

Timing of Euro 6...

- Euro 6 NEW registrations:
 - From 31st December 2013
- Euro 5 vehicles built up to 30th Sept 2013:
 - Derogation for registration up to 31st Dec 2014
- Euro 5 vehicles built after the 30th Sept 2013 build deadline
 - will have to be registered by 31st Dec 2013



Euro 6 challenges...

EURO 6

- More cooling - cab floor increased height/more steps
- Chassis packaging - limited space / flexibility
- Increased unladen weight
- Fuel & AdBlue consumption
- Higher repair and maintenance costs
- Increased capital cost



....for vehicle manufacturers

New PACCAR Euro 6 engines...

EURO 6



PX-5	PX-7	MX-11	MX-13
4.5 litre	6.7 litre	10.8 litre	12.9 litre
150-210hp	220-310hp	290-440hp	410-510hp
Common Rail Fuel Injection			
Variable Geometry Turbocharger			
Exhaust Gas Recirculation			
Diesel Particulate Filter & Selective Catalytic Reduction			

Low emissions, high efficiency...

EURO 6

Optimised combination of:

- Selective catalytic reduction
 - Improved efficiency
- Diesel particulate filter
 - Passive and active regeneration

- Common rail
- EGR / air management system
 - smartly controlled cooled actuators: VTG, EGR valve, back pressure valve
- Engine management (modes)

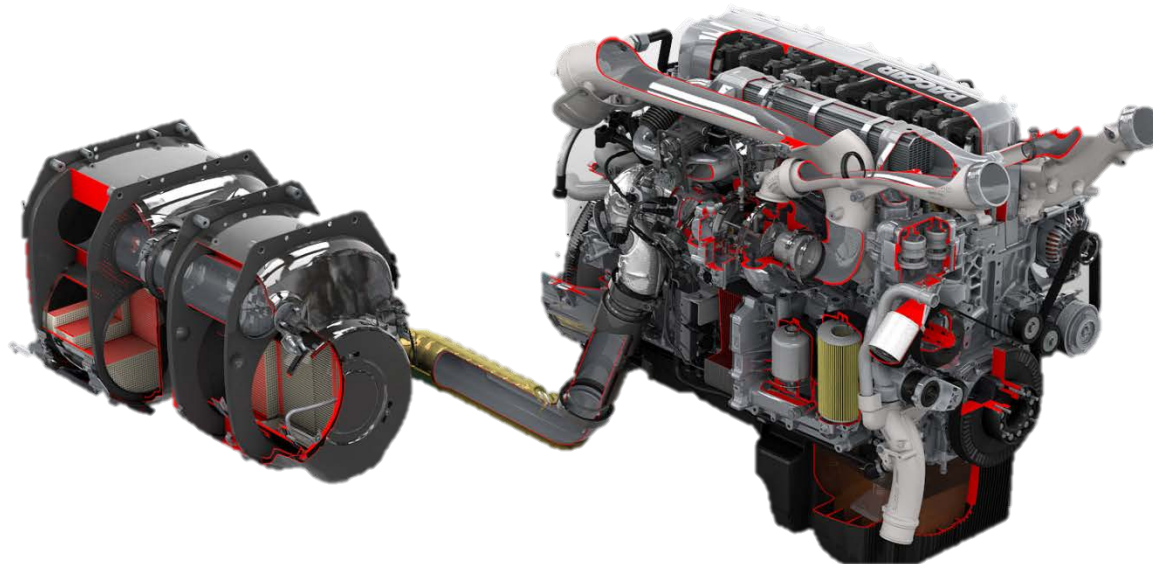

Low emissions, high efficiency...

EURO 6

Common rail fuel injection:

- Very high pressure
 - up to 2,500 bar
- Injection flexibility & precision...
 - Possibility for pre and post injection

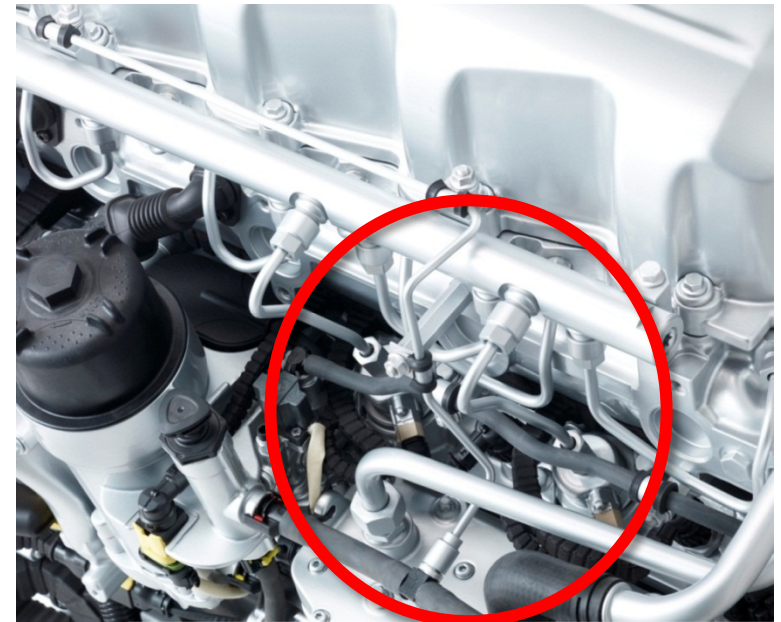
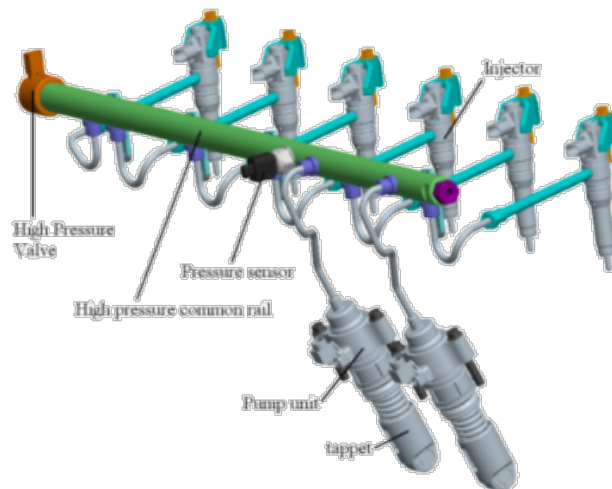

Exhaust Gas Recirculation

EURO 6

EGR cooling circuit increases radiator heat load

Variable Geometry Turbocharger - maintains correct pressure differential across the engine & control EGR / charge flow

Recirculated exhaust gas dilutes the oxygen concentration in the cylinder to lower peak combustion temperatures & lower NOx

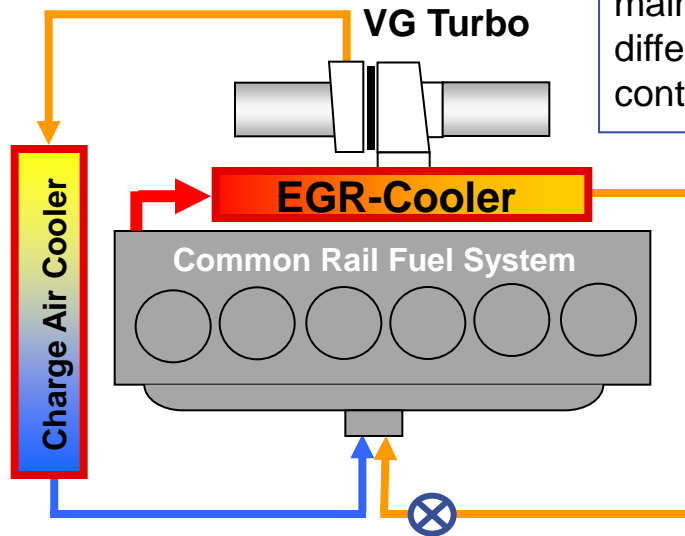

Exhaust gas is cooled before mixing it with incoming air

Low emissions, high efficiency...

EURO 6

Variable turbo geometry:

- Sliding nozzle VTG
- Improved efficiency across all engine speeds & loads
- Good transient response
- Exhaust brake function
- Enhances EGR control

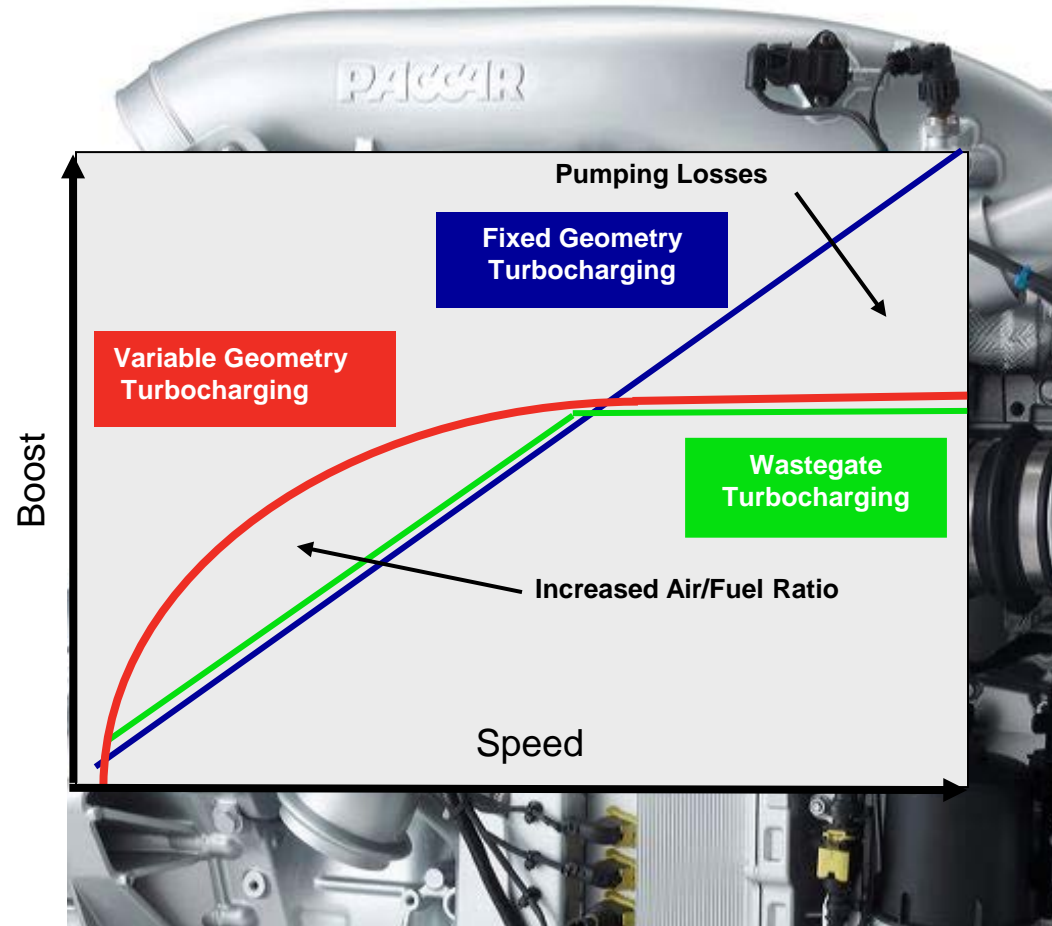

Low emissions, high efficiency...

EURO 6

Exhaust
After treatment
System

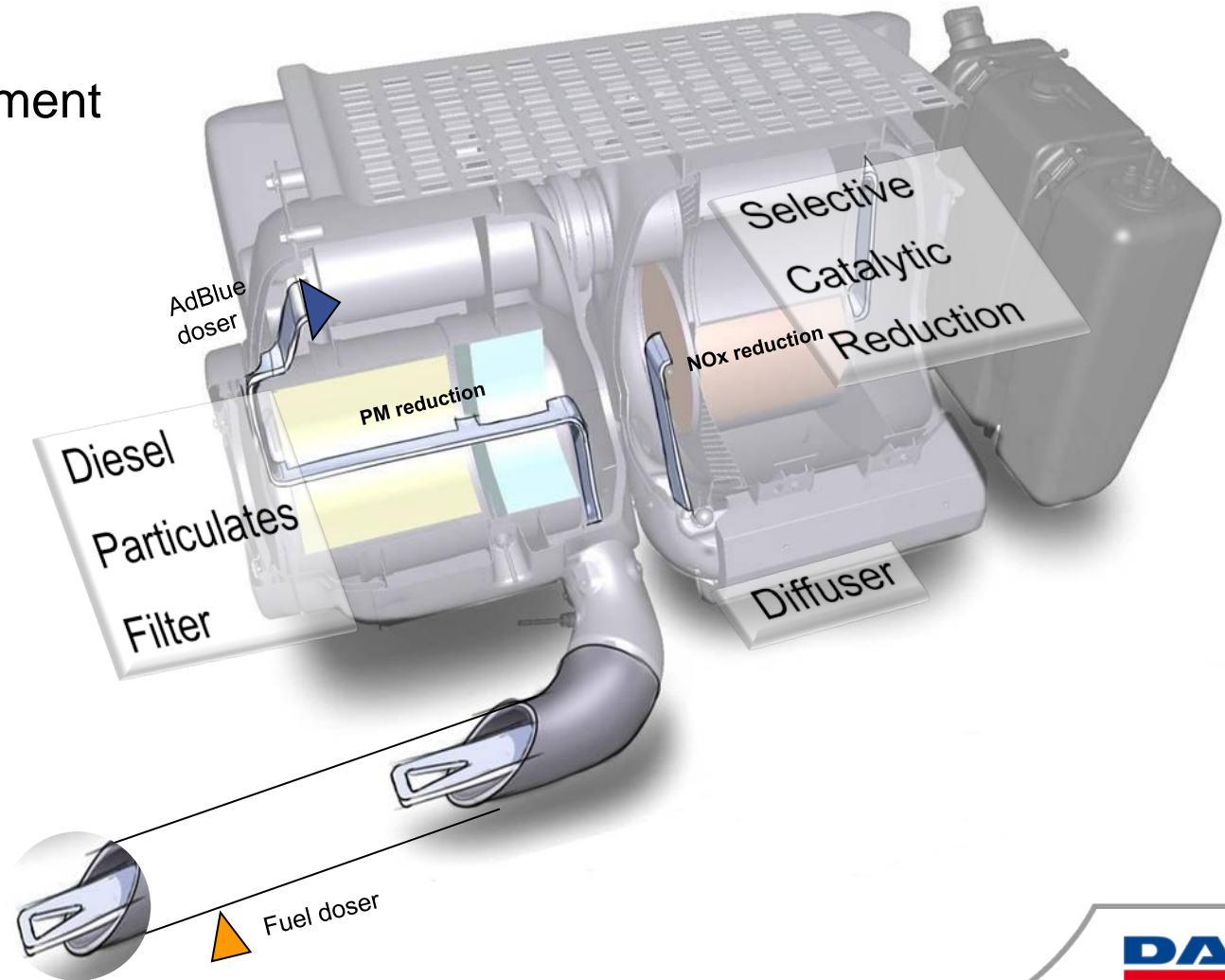

Low emissions, high efficiency...

EURO 6

Diesel particulate filter:

- Closed system - 99% filtration
- Focus on passive regeneration
 - Cordierite soot filter with smart coating
 - Exhaust gas temperature and composition
 - Insulated exhaust pipes
- Low back pressures
- Exchangeable, cleanable filter
 - Long ash cleaning intervals - up to 3 years / 500,000 km



CF & XF

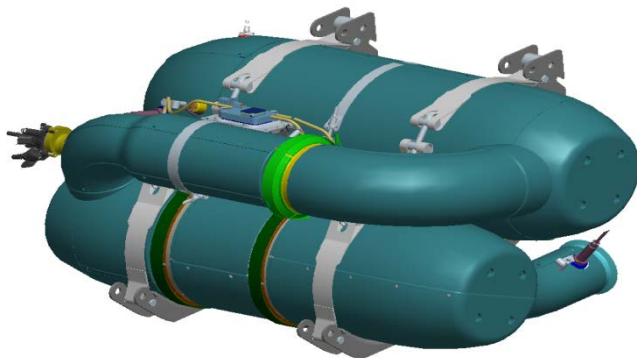

LF

Low emissions, high efficiency...

EURO 6

Selective Catalytic Reduction:

- New Airless doser
- New catalyst
 - High efficiency at low temperatures

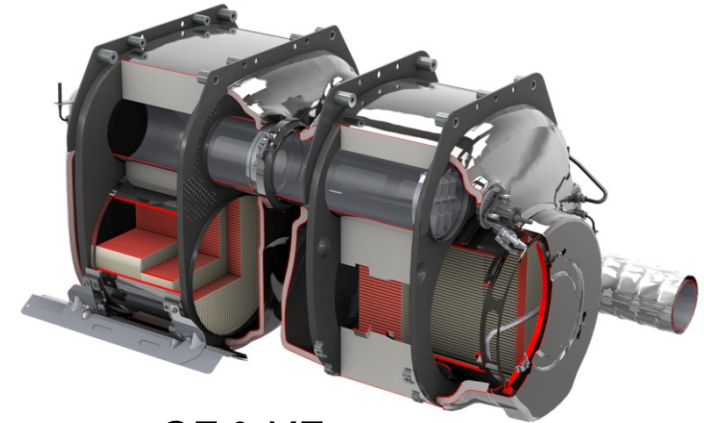

CF & XF

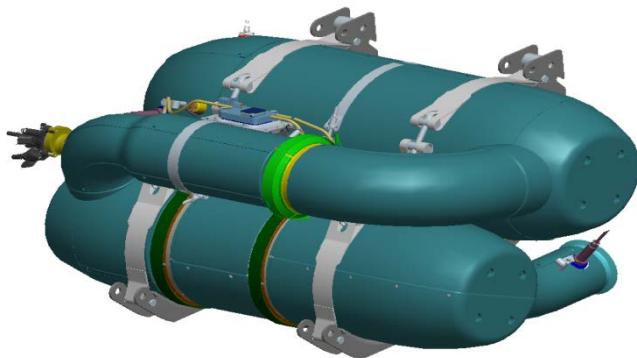

LF

EURO 6



XF



CF

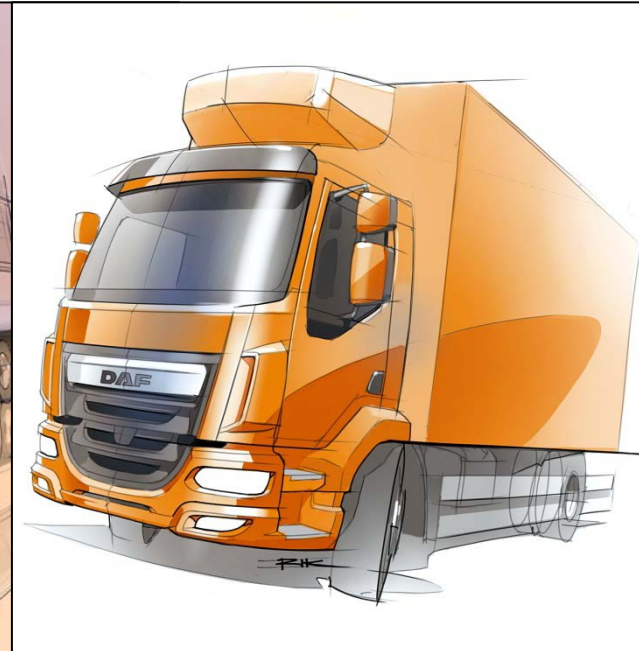

LF

Coping with the cooling challenge... *EURO 6*

- Large Grille
- Wider radiators - increased surface for efficient cooling:
 - Fan engagement reduced
- Large Intercooler - for fuel efficiency
- Minimal height changes for easy access

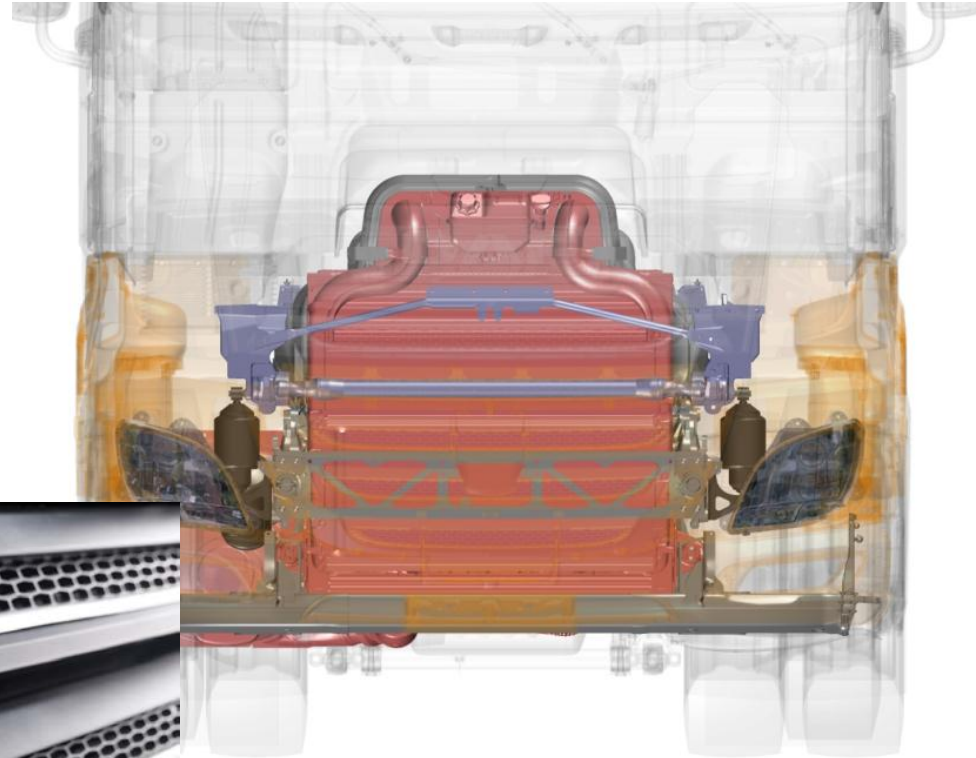

Chassis packaging...

EURO 6

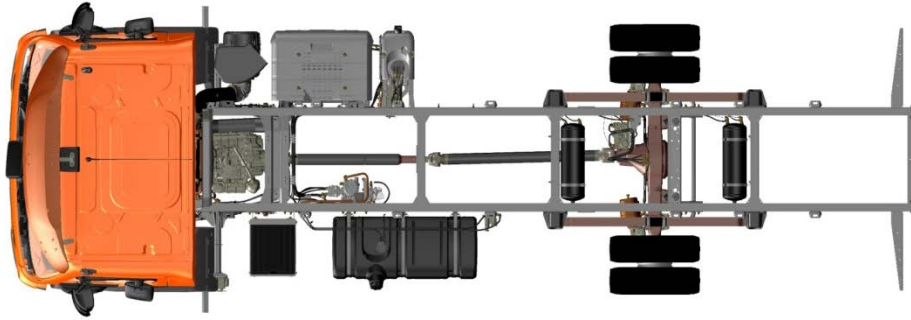

- Smart solutions

- AdBlue tank under cab on tractors
- Alternative battery installations

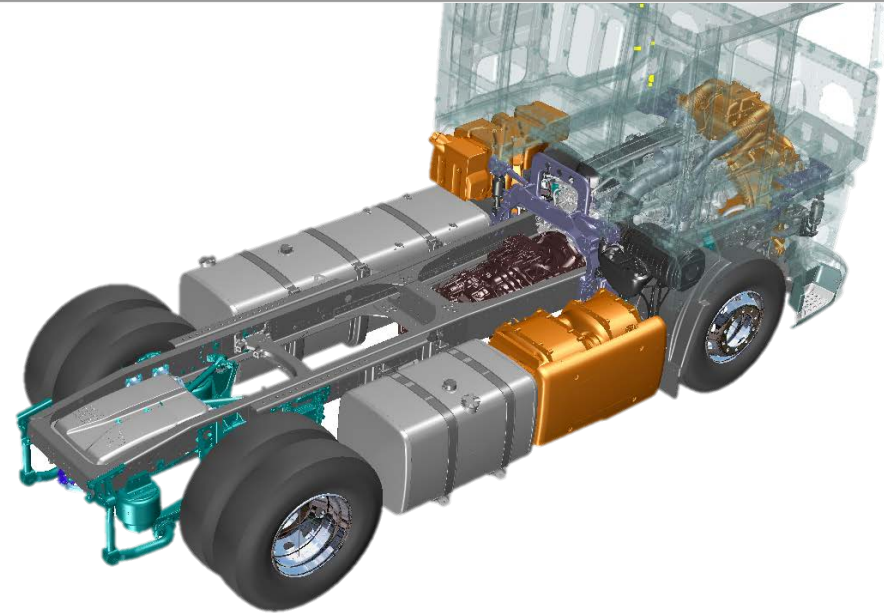

Maintaining fuel efficiency...

EURO 6

- Design target – to match today's fuel economy
 - Common rail fuel injection, optimised combustion
 - Improved cooling - direct mounted fan works less
 - Improved intercooling
 - Larger air intake - for clean cool air
 - Improved aerodynamics
 - AS-Tronic enhancements - Eco-roll, fast shift, soft cruise
 - Driver Performance Assistant
 - Faster axle ratios/less oil
 - Smart ancillaries such as
 - Air compressor
 - Two speed water pump

- AdBlue consumption reduced due to EGR and Improved NOx conversion rate



The payload challenge

EURO 6

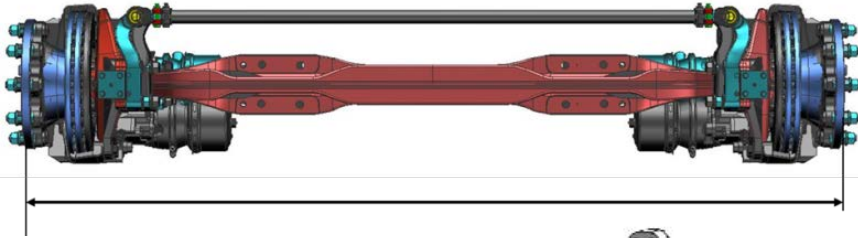

New Front axle

- Standard: 8.0t, optional: 9.0t
- Wider track: 2.55m overall width

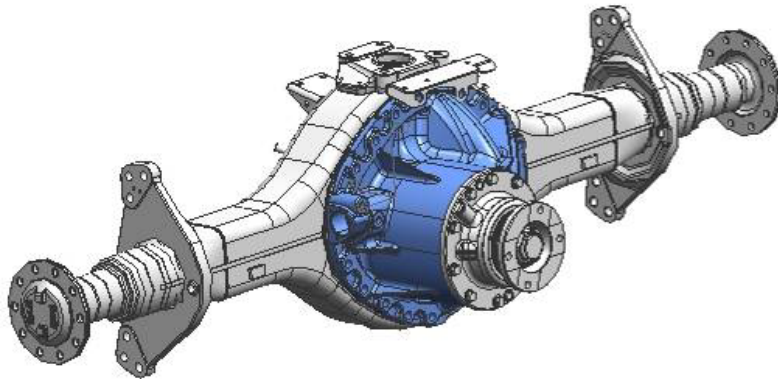

New Rear Axle

- 13 tonne carrying capacity
- 44 tonne GCW: 460bhp/2300Nm
- Approx. 40kg weight reduction
- Fast ratios to 2.38:1 for 1160 rpm cruising

New Rear suspension

- Stabilink type; anti-roll bar and reaction rods combined
- Improved ride and handling
- Approx. 60kg weight reduction

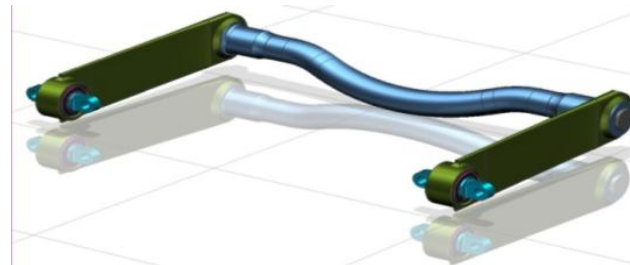
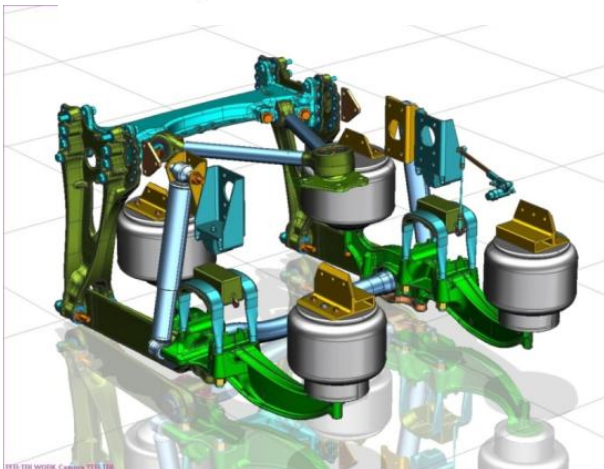

Uptime & Maintenance...

EURO 6



- Excellent Maneuverability
 - Good approach angle
 - Galvanized steel bumper
 - Lexan light covers including fog lights
 - Easy bulb change
 - Integrated day-time running lights
-
- Up to 150,000 kms oil change intervals
 - Integrated heated water separator
 - Up to 500,000 kms ash cleaning intervals
 - Improved Brake Integration & Engine braking
 - Similar R&M costs to Euro 5

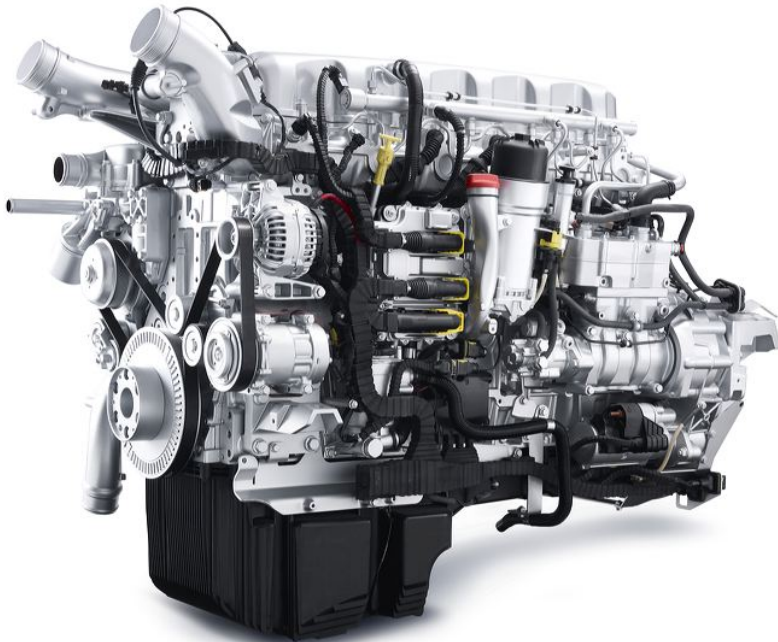

Comfort, Space & Practicality....

EURO 6



LF



XF

Driver Performance Assistant

EURO 6



Focus on ~~X~~ economy; Anticipation, Shifting, ~~C~~ Braking, General fuel saving ~~L~~ advice

Common themes: LF=CF=XF

- SCR & cooled EGR : cleanest ever exhaust
- Variable Geometry Turbocharger : more responsive, improved engine braking
- Common rail fuel injection : very high pressure, better control & quieter
- Increased cooling capacity: up to 30% more, less parasitic losses
- New chassis frame & layout: similar fuel capacity and increased AdBlue range
- Weight increase model dependent ; +0kg to +250kg
- Driveline enhancements; improved performance and economy benefits
- Driver Performance Assistant: to encourage fuel efficiency and driving standards
- Fuel economy at Euro 5 levels
- Less AdBlue usage: 2-3%
- Oil change intervals: same as Euro 5 - up to 150,000kms
- Galvanised steel front bumper: lights mounted above, 'Lexan' covers
- High capacity DPF: Minimised regeneration & ash cleaning

Focus on total cost of operation.....

Environmental: air quality and CO₂ emissions...

Noxious matter (NO_x, PM):



- Acid rain, air toxicity, smog, global warming...
 - Technology known and available
 - Harmfulness determined by age vehicle parc

Greenhouse gases (CO₂):

- Global warming, sustainability...
 - Reduction of fuel consumption
 - Use of alternative fuels
 - New vehicle concepts

Euro 6 - cleanest ever?



Continuous development – less fuel, less CO₂

New DAF LF, CF & XF

